

REVISIONS			
ECN NO.	DATE	DESCRIPTION	APPROVED
		PRODUCTION RELEASE	

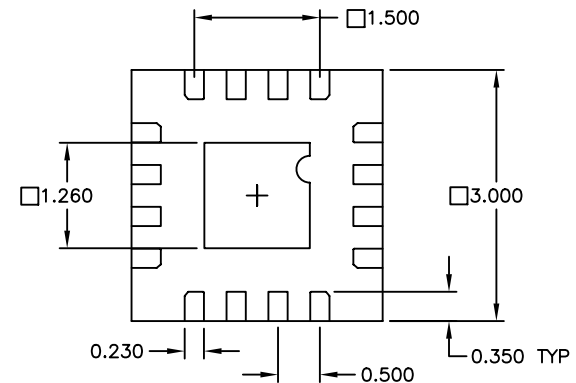

NOTES

- MATERIALS:**
LEAD FRAME: COPPER 194FH, THK = 0.203±0.008
BODY: SEMICONDUCTOR MOLDING EPOXY, CONTACT QUIK-PAK FOR DETAILS.
- FINISH:**
LEAD FRAME: ELECTROLESS NICKEL PER MIL-C-26074, CLASS 1, 100 TO 300 MICROINCHES (2.5um - 7.6um) THICK.
GOLD PLATE PER MIL-G-45204, TYPE 3, GRADE A, CLASS 1 (40 TO 80 MICROINCHES (1um - 2um) THICK).
BODY SURFACE FINISH: VDI 21-24 (1.12-1.6 Ra).
- PACKAGE MISMATCH:** BODY OFFSET TO LEAD FRAME = 0.076mm MAX
- UNLESS OTHERWISE SPECIFIED, RADIUS ON ALL MOLDED EDGES AND CORNERS = 0.25mm MAX.**
- PACKAGE CONFORMS TO JEDEC MO-220.**

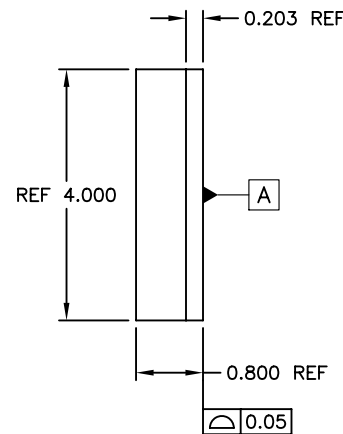
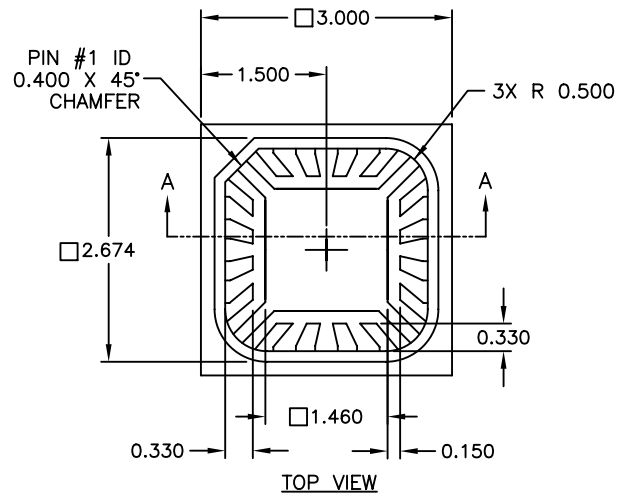
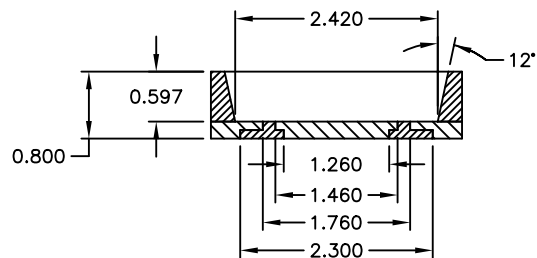

SECTION A-A

THIRD ANGLE PROJECTION

UNLESS OTHERWISE SPECIFIED DIMENSIONS ARE IN MILLIMETER TOLERANCES ARE:

X.XX ± 0.15 X.XXXX ± ---

X.XXX ± 0.050 ANGLES: ± 1°

DO NOT SCALE DRAWING

DRAWN BY	CAD DEPT.	DATE	4/22/10
APP BY	STEVE S.	DATE	4/22/10
CUSTOMER	---		
THIS DOCUMENT CONTAINS INFORMATION PROPRIETARY TO QUIK-PAK, AND REPRODUCTION IN ANY FORM IS NOT PERMITTED WITHOUT WRITTEN AUTHORIZATION FROM QUIK-PAK, DIV OF DELPHON IND.			

QUIK-PAK
www.icproto.com
10987 VIA FRONTERA
SAN DIEGO, CA. 92127
PHONE: (858) 674-4676 FAX: (858) 674-4681

3mm X 3mm
QFN 16 LEAD 0mPP

SIZE	PART NO.	REV
A	QP-QFN16-3MM-.5MM	A1
SCALE	CAD FILE	SHEET 1 OF 1